

- ① PISTON ROD SCRAPER
PROLONGS CYLINDER & PISTON ROD LIFE
BY PROVIDING POSITIVE EXCLUSION OF
FOREIGN MATTER
- ② GLAND NUT
PHOS. BRONZE, SCREWED TYPE FOR EASY
ADJUSTMENT AND REPLACEMENT (WITH
LOCKING PROVISION)
- ③ GLAND
PRECISION MADE ALL STEEL FOR MAXIMUM
STRENGTH.
- ④ GLAND PACKING
EXCELLENT LOW & HIGH PRESSURE
MECHANICALLY ACTIVATED MULTI-LIP ROD SEAL.
- ⑤ GLAND SEAL
O-RING FOR POSITIVE GLAND SEALING
- ⑥ CYLINDER BARREL
MANUFACTURED FROM COLD DRAWN SEAMLESS
TUBE, HONED FOR LONG SEAL LIFE.
- ⑦ PISTON ROD
MANUFACTURED FROM HARD CHROME PLATED
ALLOY STEEL.
- ⑧ PISTON SEAL
O-RING FOR POSITIVE SEALING.
- ⑨ PISTON
2 PIECE STEEL PISTON
- ⑩ PISTON PACKING
ROBUST DESIGN WITH WEAR RINGS
FOR POSITIVE SEALING AND LONG LIFE
- ⑪ PISTON NUT
GUARANTEES POSITIVE PISTON RETENTION
- ⑫ PORTS
STANDARD B.S.P.P. PORTS
- ⑬ PISTON LOCKING SCREW
GRUB SCREW FOR POSITIVE LOCKING.
- ⑭ END CAP

CYLINDER SPECIFICATION

DOUBLE ACTING
NON CUSHIONED
2000 P.S.I. WORKING PRESSURE
3000 P.S.I. NON SHOCK
-40°C TO +80°C WORKING TEMPERATURE

GENERAL ARRANGEMENT



HR SERIES
HYDRAULIC CYLINDERS

PAGE NO.	1
ISSUE	1
DATE	1.11.97

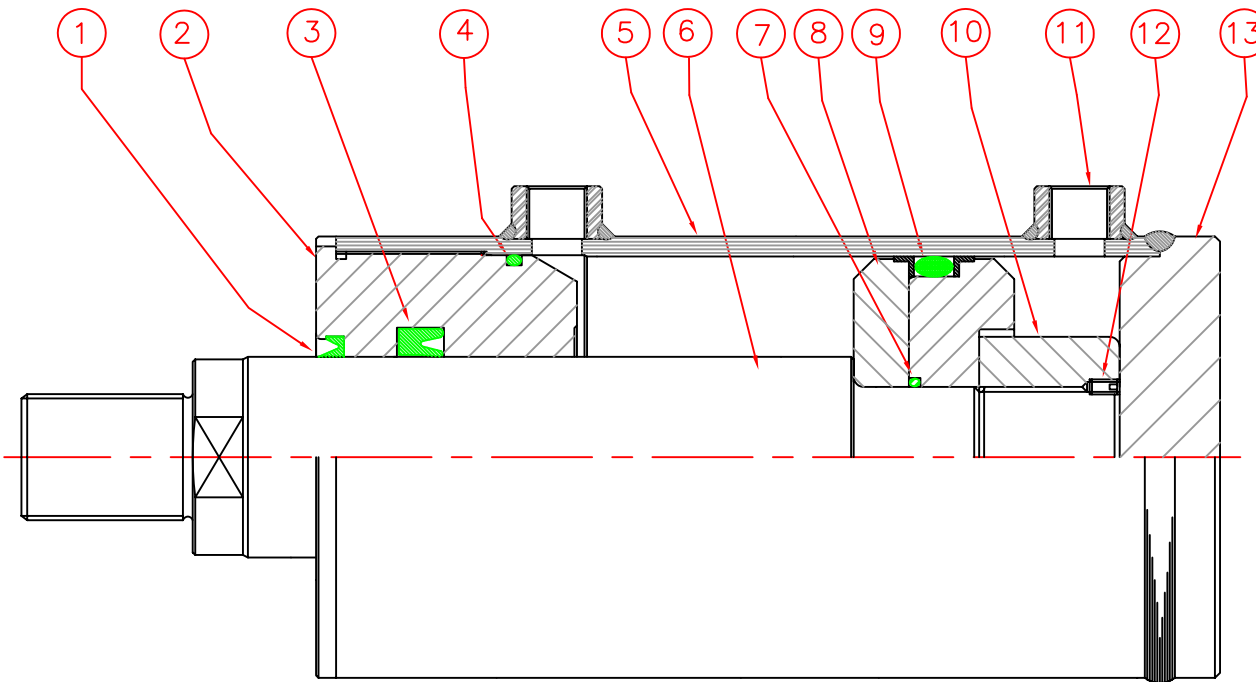

- ① PISTON ROD SCRAPER
PROLONGS CYLINDER & PISTON ROD LIFE
BY PROVIDING POSITIVE EXCLUSION OF
FOREIGN MATTER
- ② GLAND
PRECISION MADE FROM CAST IRON.
- ③ ROD SEAL
LOW FRICTION, HIGH PERFORMANCE
GENERAL PURPOSE SEAL.
- ④ GLAND SEAL
O-RING FOR POSITIVE GLAND SEALING
- ⑤ CYLINDER BARREL
MANUFACTURED FROM COLD DRAWN SEAMLESS
TUBE, HONED FOR LONG SEAL LIFE.
- ⑥ PISTON ROD
MANUFACTURED FROM HARD CHROME PLATED
ALLOY STEEL.
- ⑦ PISTON SEAL
O-RING FOR POSITIVE SEALING.
- ⑧ PISTON
2 PIECE STEEL PISTON
- ⑨ PISTON PACKING
ROBUST DESIGN WITH WEAR RINGS
FOR POSITIVE LONG LIFE
- ⑩ PISTON NUT
GUARANTEES POSITIVE PISTON RETENTION
- ⑪ PORTS
STANDARD B.S.P.P. PORTS
- ⑫ PISTON LOCKING SCREW
GRUB SCREW FOR POSITIVE LOCKING.
- ⑬ END CAP

CYLINDER SPECIFICATION

DOUBLE ACTING
NON CUSHIONED
2000 P.S.I. WORKING PRESSURE
3000 P.S.I. NON SHOCK
-40°C TO +80°C WORKING TEMPERATURE

GENERAL ARRANGEMENT



HSH SERIES
HYDRAULIC CYLINDERS

PAGE NO.	2
ISSUE	1
DATE	1.11.97

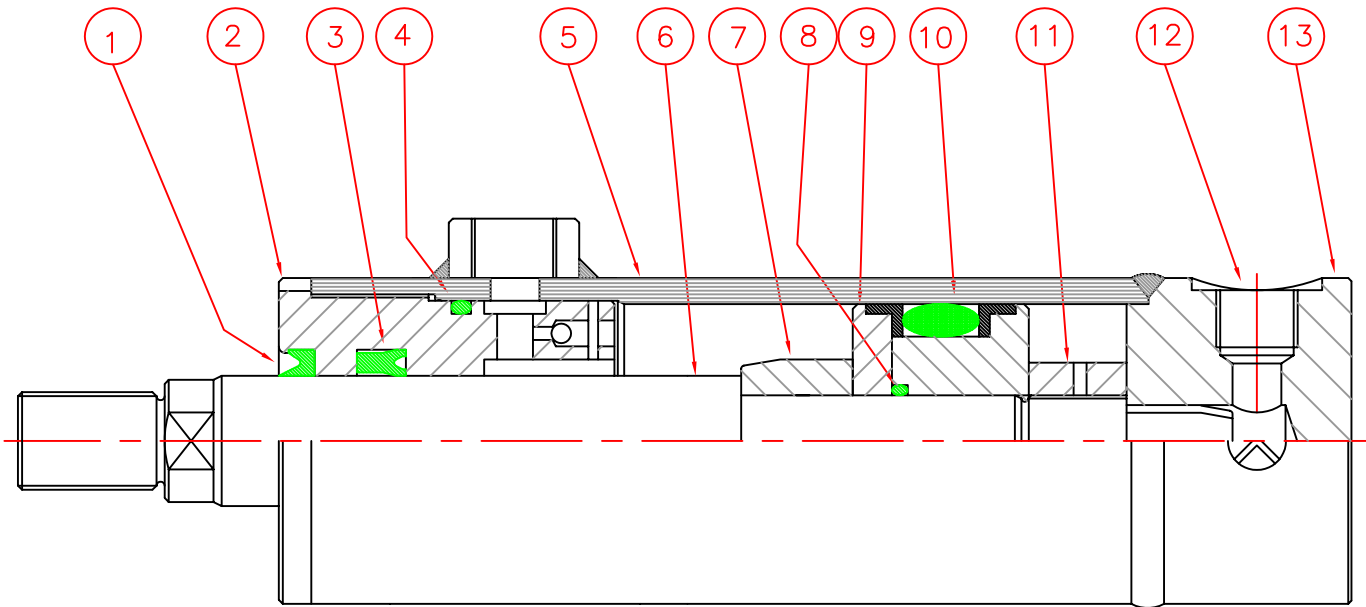

- ① PISTON ROD SCRAPER
PROLONGS CYLINDER & PISTON ROD LIFE
BY PROVIDING POSITIVE EXCLUSION OF
FOREIGN MATTER
- ② GLAND
PRECISION MADE FROM CAST IRON
WITH INBUILT NON ADJUSTABLE CUSHION
- ③ ROD SEAL
LOW FRICTION, HIGH PERFORMANCE
GENERAL PURPOSE SEAL.
- ④ GLAND SEAL
O-RING FOR POSITIVE GLAND SEALING
- ⑤ CYLINDER BARREL
MANUFACTURED FROM COLD DRAWN SEAMLESS
TUBE, HONED FOR LONG SEAL LIFE.
- ⑥ PISTON ROD
MANUFACTURED FROM HARD CHROME PLATED
ALLOY STEEL.
- ⑦ CUSHION SLEEVE
BRONZE LOADED FOR CLOSE TOLERANCE FIT
- ⑧ PISTON SEAL
O-RING FOR POSITIVE SEALING.
- ⑨ PISTON
2 PIECE STEEL PISTON
- ⑩ PISTON PACKING
ROBUST DESIGN WITH WEAR RINGS
FOR POSITIVE SEALING AND LONG LIFE
- ⑪ PISTON NUT
GUARANTEES POSITIVE PISTON RETENTION
- ⑫ PORTS
STANDARD B.S.P.P. PORTS
- ⑬ END CAP
WITH ADJUSTABLE CUSHIONS
- ⑭ CUSHION NEEDLE VALVE
ALLOWS CUSHION ADJUSTMENT
- ⑮ CUSHION CHECK VALVE

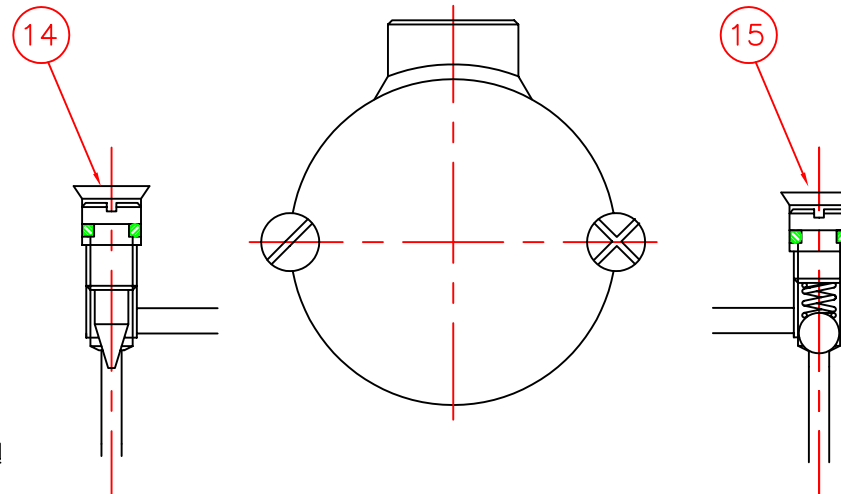

CYLINDER SPECIFICATION
 DOUBLE ACTING
 CUSHIONED BOTH ENDS
 2000 P.S.I. WORKING PRESSURE
 3000 P.S.I. NON SHOCK
 -40°C TO +80°C WORKING TEMPERATURE

CUSHION ASSEMBLY – REAR VIEW
 REAR CUSHIONS ARE ADJUSTABLE
 FRONT CUSHIONS DO NOT ALLOW FOR ADJUSTMENT